

PEREBO float PT03

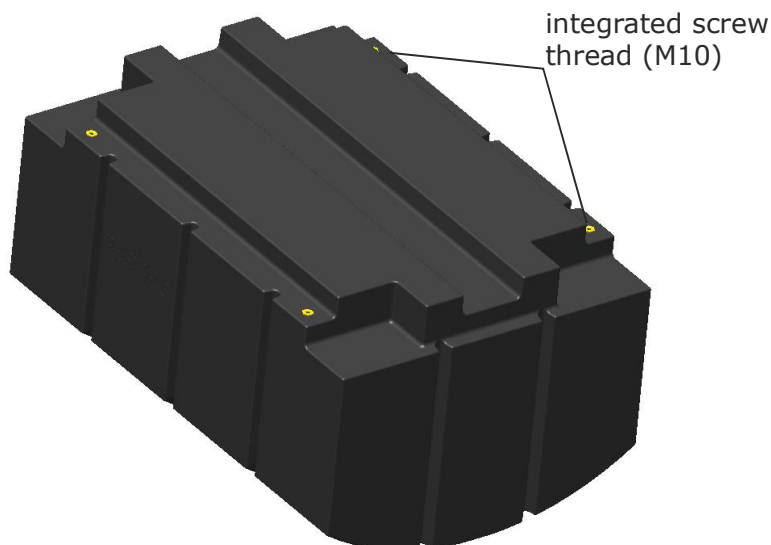

technical data	
dimensions L/W/H:	115,0 / 78,0 / 60,0cm
wall thickness :	approx. 8mm
self-weight:	approx. 26kg
material:	polyethylene
screw threads M10:	6x (4 above, 2 below)
standard color:	black
(other colors on request)	

load capacity (approx. values)	
immersion depth [cm]	load capacity [kg]
5,0	-6,0
10,0	28,0
15,0	72,0
20,0	117,0
25,0	161,0
30,0	206,0
35,0	250,0
40,0	295,0
(self-weight deducted)	
1/2 immersion depth= 30cm	
max. recommended immersion depth= 40cm	

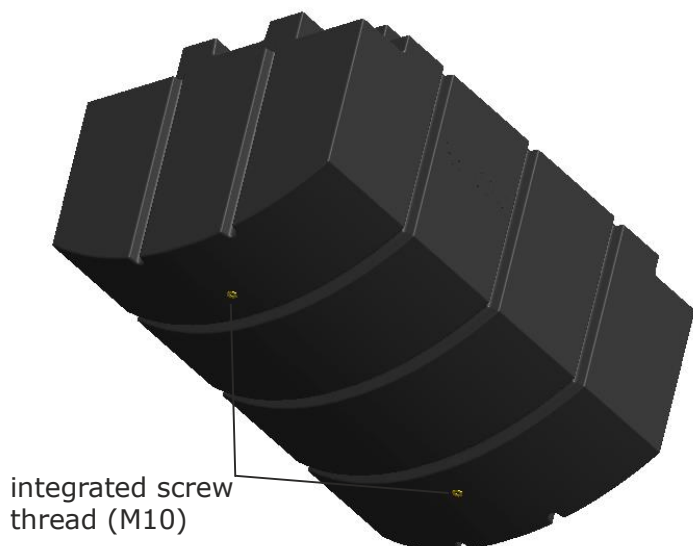

top view

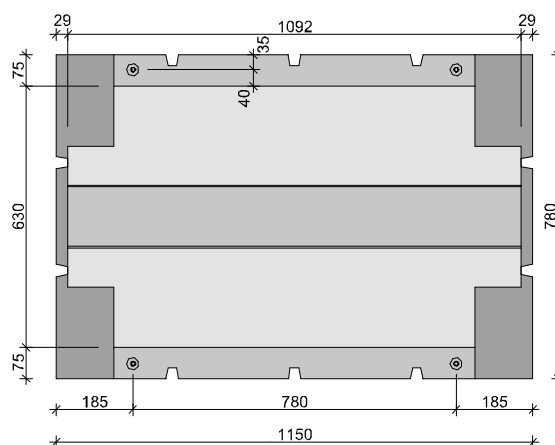

front view

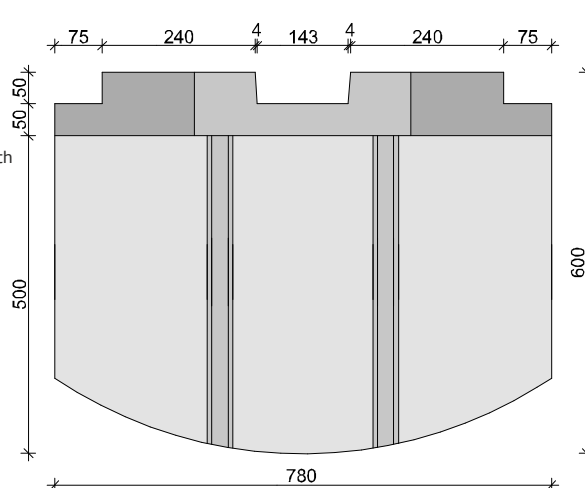

Important note:

Please note that it may come to dimensional deviations as a result of production and at different outside temperatures.