

# Modular Float System - PT06

## Front Section

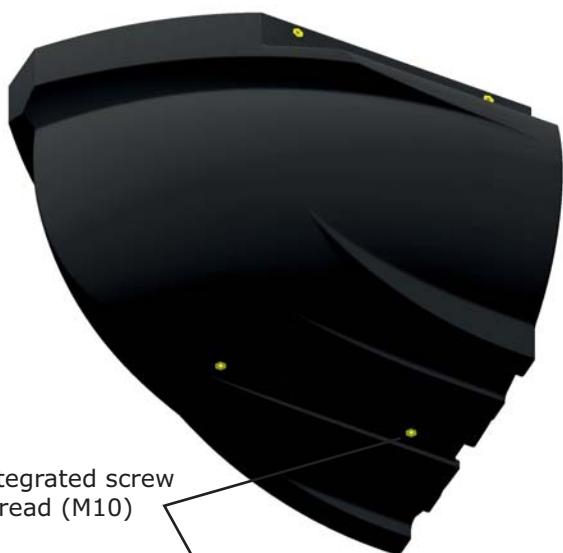

integrated screw thread (M10)



40cm immersion depth

technical data	
dimensions L/W/H:	103,0 / 90,0 / 70,0cm
wall thickness :	approx. 7-8mm
self-weight:	approx. 27kg
material:	polyethylene
screw threads M10:	10 pcs. in total
standard color:	black
(other colors on request)	

load capacity (approx. values)	
immersion depth [cm]	load capacity [kg]
5,0	-11,0
10,0	3,0
15,0	25,0
20,0	50,0
25,0	78,0
30,0	107,0
35,0	138,0
<b>40,0</b>	<b>169,0</b>
45,0	202,0
(self-weight deducted)	
max. recommended immersion depth= 40cm	

side view

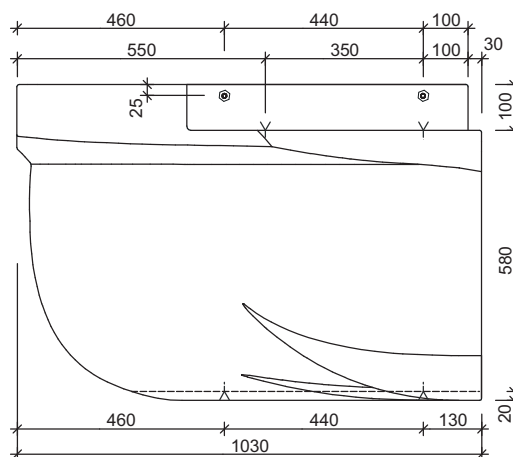

front view

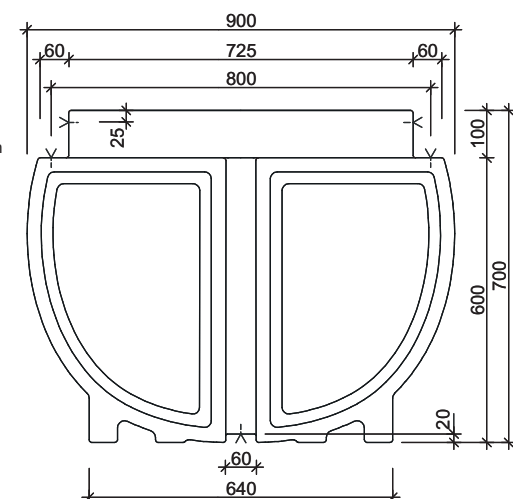

**Important note:**

Please note that it may come to dimensional deviations as a result of production and at different outside temperatures. Therefore, always measure the thread distances directly on the pontoons.