

Modular Float System - PT06

Middle Section

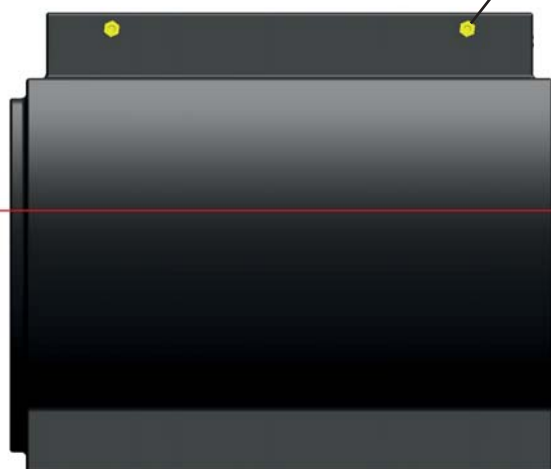

integrated screw thread (M10)



40cm immersion depth

technical data	
dimensions L/W/H:	82,5 / 90,0 / 70,0cm
wall thickness :	approx. 7-8mm
self-weight:	approx. 29kg
material:	polyethylene
screw threads M10:	11 pcs. in total
standard color:	black
(other colors on request)	

load capacity (approx. values)	
immersion depth [cm]	load capacity [kg]
5,0	-9,0
10,0	16,0
15,0	42,0
20,0	72,0
25,0	103,0
30,0	137,0
35,0	171,0
40,0	206,0
45,0	240,0
(self-weight deducted)	
max. recommended immersion depth= 40cm	

side view

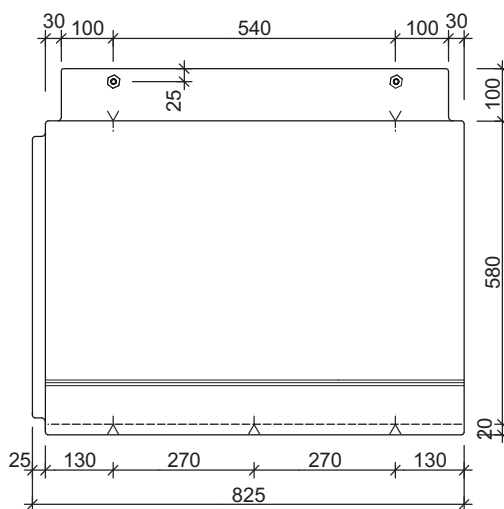

front view

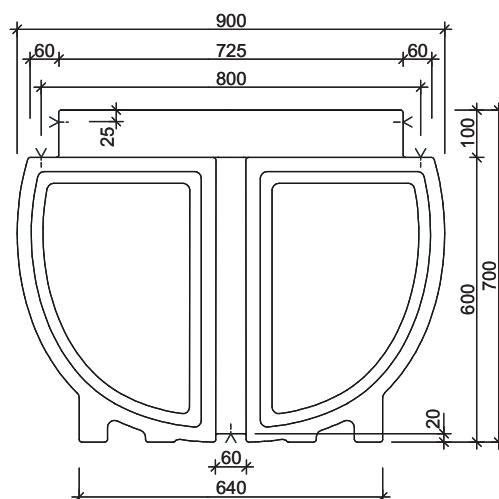

Important note:

Please note that it may come to dimensional deviations as a result of production and at different outside temperatures. Therefore, always measure the thread distances directly on the pontoons.